

MOTORE STANDARD DIMENSIONI IM B5 E IM B14 NORMALE E BI-ALBERO

Alla categoria B5 appartengono anche le forme costruttive V1 e V3. Per la versioni B5 sono disponibili due tipi di flangia, una standard ed una ridotta. Alla categoria B14 appartengono anche le forme costruttive V18 e V19

SINGLE AND DOUBLE SHAFT END STANDARD MOTOR IM B5 AND IM B14 DIMENSIONS

To the B5 type of installation belong also the V1 and V3 types of installation. Two kinds of flange are available for the B5 type of installation, a standard flange and a reduced one. To the B14 type of installation belong also the V18 and V19 types of installation.

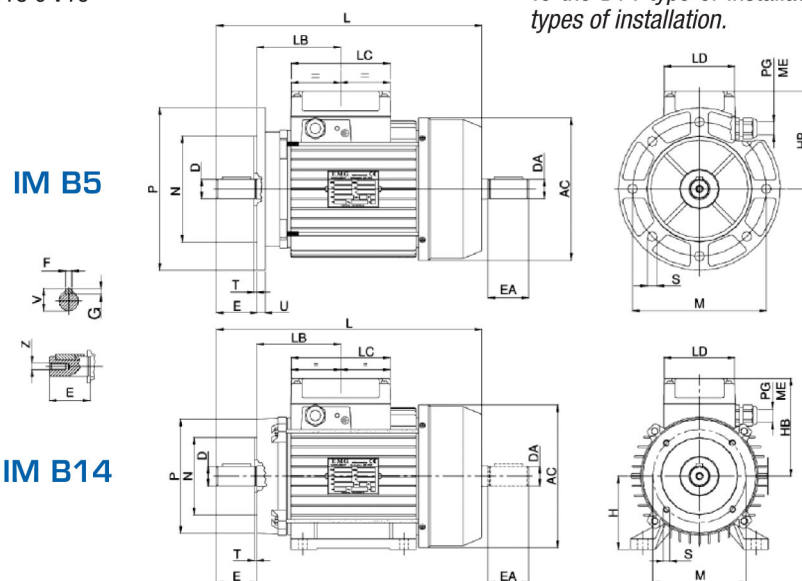

MEC	INGOMBRO / OVERALL (mm)		ALBERO / SHAFT (mm)				COPERCHIO / TERMINAL-BOX (mm)				
	HB	L	D/DA	E/EA	V	Z	LB	LC	LD	ME	PG
56	88	188	9	20	10,2	M 4	70	90	79	M12	9
63	95	207	11	23	12,5	M 4	78	101	79	M16	-
71	104	243	14	30	16	M 5	90	111	79	M16	-
80	115	280	19	40	21,5	M 6	101	123	88	M20	-
90S	120	305	24	50	27	M 8	102	123	88	M20	-
90L	120	330	24	50	27	M 8	104	123	88	M20	-
100L	134	363	28	60	31	M 10	92	90	90	M25	16
112M	150	383	28	60	31	M 10	104	112	112	M25	16
132S	178	458	38	80	41	M 12	111	112	112	M25/32	16/21
132M	178	497	38	80	41	M 12	111	112	112	M25/32	16/21
160M	223	563	42	110	45	M16	150	141	141	32	21
160L	223	607	42	110	45	M16	150	141	141	32	21
180	238	698	48	110	51,5	M16	165	141	141	-	29

MEC	FLANGIA STANDARD B5 / B5 STANDARD FLANGE (mm)						FLANGIA RIDOTTA B5 / B5 REDUCED FLANGE (mm)						FLANGIA B14 / B14 FLANGE (mm)				
	M	N	P	S	T	U	M	N	P	S	T	U	M	N	P	S	T
56	100	80	118	7	3	7,5	-	-	-	-	-	-	65	50	80	M 5	2,5
63	115	95	140	9,5	3	9	-	-	-	-	-	-	75	60	90	M 5	2,5
71	130	110	160	9,5	3,5	8	115	95	140	9	3,5	8	85	70	105	M 6	2,5
80	165	130	200	12	3,5	9	130	110	160	9,5	3,5	9	100	80	120	M 6	3
90S	165	130	200	13	3,5	10	130	110	160	9,5	3,5	9	115	95	140	M 8	3
90L	165	130	200	13	3,5	10	130	110	160	9,5	3,5	9	115	95	140	M 8	3
100L	215	180	250	14	4	10	165	130	200	12	3,5	10	130	110	160	M 8	3,5
112M	215	180	250	15	4	12	165	130	200	11,5	3,5	14	130	110	160	M 8	3,5
132S	265	230	300	14	4	15	215	180	250	14	4	13	165	130	200	M 10	3,5
132M	265	230	300	14	4	15	215	180	250	14	4	13	165	130	200	M 10	3,5
160M	300	250	350	19	5	14	265	230	300	14	4	13,5	215	180	255	M12	4
160L	300	250	350	19	5	14	265	230	300	14	4	13,5	215	180	255	M12	4
180	300	250	350	19	5	16	-	-	-	-	-	-	-	-	-	-	-